



IWIS Recommended Practice

**Prepared for IWIS Panel by
OTM Consulting Ltd**

IWIS-RP-A2
April 2011



Table of Contents

Table of Contents	2
Background	4
1. Purpose and Usage.....	4
2. References	5
3. Terms and Definitions	6
4. Abbreviations.....	8
5. Schematic & Terminology	10
6. Subsea Power System Guidelines	11
6.1 Introduction	11
6.2 Options	11
6.3 Power Requirements	12
6.4 EMC	12
6.5 Redundancy.....	12
6.6 Connection to the Downhole Equipment	13
7. Communication System Guidelines	14
7.1 Introduction	14
7.2 Communications System Overview.....	14
7.3 Communication System Recommendations	15
7.4 IWCS Interfaces with Other Systems	17
8. Hydraulic System Guidelines	19
8.1 Introduction	19
8.2 Interface Options	19
8.3 Cleanliness	19
8.4 Supply control valve	19
8.5 Compatibility	19
8.6 Thermal Expansion.....	19
8.7 Fail-Safe / Failure Functionality	20
8.8 Interface Options	20
9. Xmas Tree Physical Interface System Guidelines	22
9.1 Introduction	22
9.2 EFS Function	22
9.3 Service Classes	22
9.4 Documentation.....	22
9.5 Critical Interfaces	23
9.6 System Configurations	23
9.7 Reliability	24
9.8 Service Conditions.....	25
9.9 Mechanical Performance Requirements	26
9.10 Electrical Performance Requirements	26
9.11 Qualification Test Requirements	26
9.12 Factory Acceptance Test (FAT).....	35

List of Tables

Table 1 Terms and Definitions	6
Table 3 Service Classes	22
Table 4 Service Conditions.....	25
Table 5 Mechanical Performance Requirements	26
Table 6 Electrical Performance Requirements.....	26
Table 7 Contact Resistance	26
Table 8 Insulation Resistance	27
Table 9 Proof Voltage.....	27
Table 10 Hydrostatic Withstand Pressure Test.....	27
Table 11 Turbid Testing.....	28



Table 12 Misalignment Test	29
Table 13 Thermal Shock Test	30
Table 14 Flooded Termination Test	31
Table 15 Seal Hydrostatic Pressure Test.....	32
Table 16 Mechanical Shock Test	33
Table 17 Vibration Test	33
Table 18 Cyclical Pressure & Temperature Test	34
Table 19 Helium Leak Test.....	34
Table 20 Shell Continuity Test	34
Table 21 Factory Acceptance Test.....	35

List of Figures

Figure 1 Production Control System & IWIS Schematic	10
Figure 2 Connection to Downhole Equipment.....	13
Figure 3 The IWIS Communication Architecture	14
Figure 4 Negotiation of IP Address between IWE and SEM.....	16
Figure 5 Hydraulic Interface Direct Control	20
Figure 6 Hydraulic Interface IWIS Type 3 Hydraulic Module	21
Figure 7 Horizontal Xmas Tree Feedthrough System Configuration	23
Figure 8 Vertical Xmas Tree Feedthrough System Configuration.....	24



Background

The Intelligent Well Interface Standard, or IWIS, is a joint industry project whose mission is 'to assist the integration of downhole power and communication architectures, subsea control systems and topsides by providing recommended specifications (and standards where appropriate) for power and communication architectures and other associated hardware requirements'.

The main goals of the IWIS Panel have been to:

- To reduce complexity
- To reduce technical risk
- To reduce direct and indirect costs
- To increase flexibility of compatible systems
- To allow wider choice of supplier
- To reduce lead times for hardware
- To allow easier definition and implementation of subsea infrastructure
- To reduce tender overheads
- To spread best practice

The IWIS Recommended Practice document has been developed to consolidate the work and provide a practical user-document from the Intelligent Well Interface Standardisation (IWIS) Industry Panel. This document should be used in conjunction with the International Standard ISO 13628 - Part 6 2006.

1. Purpose and Usage

ISO13628 – Part 6 provides the authoritative source to implement an IWIS interface. This document provides additional detailed information to assist anyone needing to understand or work with the IWIS hardware and / or software.

Supporting information in the recommended practice is split into the follow areas

- Subsea Power System
- Communication System
- Hydraulic System
- Xmas Tree Physical Interface System

Detailed information in each section is referenced back to the original ISO13628 – Part 6 document by section number.

ISO 13628 – Part 6 is available from ISO www.iso.org.

OTM and the members of the IWIS Panel cannot be held responsible for any errors or omissions in this document.



2. References

- IWIS Website: www.iwis-jip.com
- ISO Website: www.iso.org
- OTM Website: www.otmnet.com
- ISO 10423, Petroleum and natural gas industries – Drilling and production equipment – Wellhead and Christmas tree equipment
- ISO 13628-3, Petroleum and natural gas industries – Design and operation of subsea production systems – Part 3: Through flowline (TFL) systems
- ISO 13628-4, Petroleum and natural gas industries – Design and operation of subsea production systems – Part 4: Subsea wellhead and tree equipment
- ISO 13628-6, Petroleum and natural gas industries – Design and operation of subsea production systems – Part 6: Subsea production control systems
- ISO 15156 (NACE MR0175), Petroleum and natural gas industries – Materials for use in H₂S-containing environments in oil and gas production
- IWIS Panel 33 Members:

Aker Kvaerner	Petrobras
Baker Hughes – Baker Oil Tools	PROMORE
Baker Hughes – ProductionQuest	Roxar
BP	Schlumberger
Cameron	SEACON
ChevronTexaco	Shell
DG O'Brien	Sicom
Dril-Quip	Siemens
ENI	Statoil
FMC	Total
GE Sensing	Tronic
Hydro	Vetco
JP Kenny	Weatherford
Luna Energy	WellDynamics
National Coupling	Woodside
ODI	Wood Group
OTM Consulting	

- **Any enquiries or questions concerning IWIS please contact:**

OTM Consulting
Beaufort House
1 Chertsey Street
Guildford
Surrey GU1 4HA
UK
Tel: +44 1483 598000
info@otmnet.com
www.otmnet.com



3. Terms and Definitions

Terms	Definition
ACK	A transmission control character used to indicate that a transmitted message was received uncorrupted or without errors or that the receiving station is ready to accept transmissions. The receiver sends the code to the sender to indicate that the transmission has been accepted.
Alignment	Specific to stab-mate engagement interface and the mechanical and physical orientation between mating halves of a connector pair, typically the wetmate connector.
Alignment (Axial)	Alignment between connector halves associated to the proximity along the centreline of the connector related to end-face position (longitudinal tolerance) with coincident centrelines.
Alignment (Angular)	Alignment between connector halves associated with the angle formed between the centreline of one half of the connector respective to the centreline of the mating half of the connector (angular tolerance).
Alignment (Radial)	Alignment between connector halves associated with offset in a direction perpendicular to the centreline of one half of the connector respective to the centreline of the mating half of the connector (radial tolerance).
Annulus	The space formed between the production pipe and the casing or bore hole below the Tubing Hanger.
Baud	The number of signalling elements that occur each second.
Class	Service rating designation defining maximum operational pressure and temperature limits of equipment. Class A: 690 Bar a/121°C Class B: 1034 Bar a/150°C (HPHT) Class C: 1034 Bar a/177°C (HPHT)
Connector	Electric, fibre optic or hydraulic device consisting of two mating halves, one female (plug or socket), one male (receptacle or pin), that upon engaging completes the transmission circuit through the device.
Corrosion Inhibitor	A chemical additive used in acid treatments to protect iron and steel components in the well-bore and treating equipment from the corrosive treating fluid. Corrosion inhibitors generally are mixed with the treatment fluid and are formulated to be effective in protecting the metal components the fluid is likely to contact.
CSMA/CD	Carrier Sense Multiple Access With Collision Detection is a network protocol.
Downhole	That portion of a drilled and completed well within the well-bore (borehole) located below the wellhead.
Drymate	A connector with an interface capable of being engaged and disengaged many times in an ambient atmospheric environment, typically not tolerant of wetmating or being engaged in wet or moist environments.
Dual Barrier	Pressure-containment: Consisting of two independent (dissimilar) seal mechanisms at every pressure boundary with a primary and secondary seal. Electrical isolation: Consisting of two independent dielectric barrier systems or elements between the surrounding ambient media and the transmission circuit elements (electrical conductor or fibre). Dielectric fluid (e.g.: silicone oil, etc.) is not considered as one of the barrier elements.
g	The value of gravity, measured in m/s^2 .

Table 1 Terms and Definitions

Terms	Definition
Gallery	The space formed between the tubing hanger and the tree valve block.
HPHT	High Pressure, High Temperature; referring to equipment ratings in excess of 690 Bar a and 121°C; reference Class B service rating.
NAK	A transmission control character used to indicate that a transmitted message was received with errors or corrupted or that the receiving station is not ready to accept transmissions. The receiver sends the code to the sender to indicate that the transmission must be resent.
Oxygen Scavenger	A chemical that reacts with dissolved oxygen (O ₂) to reduce corrosion, such as sulphite (SO ₃ ²⁻) and bisulphite (HSO ₃ ⁻) ions that combines with oxygen to form sulphate (SO ₄ ²⁻).
Penetrator / Feedthrough	A transmission device (electrical, optical or hydraulic) inserted through a pressure vessel maintaining full pressure containment integrity of the pressure vessel (i.e. Xmas Tree).
Pressure	“Bar a” are the standard units of Pressure used in this document.
P _T	Pressure, test (maximum); 1.5 x working pressure (P _w) (Test pressure = Proof pressure).
P _w	Pressure, working (maximum).
Redundant Sealing	More than one pressure-retaining seal mechanism of a similar design.
Room Temperature	Ambient (25°±5°C).
Root Mean Square	Is the square root of the mean of the squares of the values.
RS422	American national standard ANSI/TIA/EIA-422-B is a technical standard that specifies the “electrical characteristics of the balanced voltage digital interface circuit”. It provides for data transmission using balanced or differential signalling, with unidirectional/non-reversible, terminated or non-terminated transmission lines, point-to-point or multi-drop.
Scoop Proof	The connector, by design, prevents damage to internal contacts, during misalignment of the connector bodies.
T _T	Temperature, test [also working] (maximum).
Wetmate	A connector with an interface capable of being engaged and disengaged many times by manual or remote means in ambient seawater and/or wellhead environments; also capable of being drymated.
Xmas Tree	A subsea structure consisting of valves and actuators landed remotely on a casing or wellhead through which a well is produced. A horizontal tree has the Tubing Hanger landed within the tree structure, with the tree landed on the wellhead. A vertical tree has the Tubing Hanger landed on the wellhead, then the tree structure landed.

Table 1 Terms and Definitions (continued)



4. Abbreviations

A	Amp, unit of electrical current
ACK	Acknowledgement code
ANSI	American National Standards Institute
API	American Petroleum Institute
AS	Aerospace Standard
Bar a	Bar Absolute
bps	bits per second
CSMA/CD	Carrier Sense Multiple Access With Collision Detection
CR	Contact Resistance
DCS	Distributed Control System
DH	Downhole
DHG	Downhole Gauge
DIN	Deutsches Institut für Normung eV
DIS	Draft International Standard
EFS	Electrical Feedthrough System
ESS	Environmental Stress Screening
EMC	Electro Magnetic Compatibility
EUT	Equipment Under Test
FAT	Factory Acceptance Test
FMECA	Failure Mode, Effects & Criticality Analysis
g	The value of gravity
GND	Ground, in electrical circuits
Hz	Hertz, a unit of frequency of electrical vibrations equal to one cycle per second
HP	High Pressure
HPHT	High Pressure, High Temperature
HV	High Voltage
HWPT	Hydrostatic Withstand Pressure Test
I/O	Input / Output
IEC	International Electrotechnical Commission
IEEE	Institute of Electrical and Electronic Engineers
IP	Internet Protocol
IPCP	Internet Protocol Control Protocol
IR	Insulation Resistance
iSEM	Intelligent Well Subsea Electronic Module
ISO	International Organization for Standardisation
IWC	Intelligent Well Controller
IWE	Intelligent Well Equipment
IWIS	Intelligent Well Interface Standardisation
IWCS	Intelligent Well Control System
lbf	Pound-force
LCP	Link Control Protocol



LP	Low Pressure
M	Prefix Mega-, meaning 10^6
MCS	Master Control System
m	Prefix milli-, meaning 10^{-3}
mm	millimetre
ms	millisecond
N	Newton, unit of force
NACE	National Association of Corrosion Engineers
NAK	Negative Acknowledgement code
NCP	Network Control Protocol
OLE	Object Linking and Embedding
OPC	OLE for Process Control
OSI	Open Systems Interconnection
Pa	Pascal, unit of pressure equivalent to 1 Newton per square metre
PCS	Production Control System
PLC	Programmable Logic Controller
PPP	Point to Point Protocol
psi	Pound-force per square inch, a unit of pressure
psig	psi-gauge, unit of pressure relative to atmospheric pressure at sea level.
PSL	Product Specification Level
Px	Pressure Transducer
RMS	Root Mean Square
ROT	Remotely Operated Tool
ROV	Remotely Operated Vehicle
RP	Recommended Practice
Rx	Receive
SC	Sub-Committee (of a TC)
SCM	Subsea Control Module
SEM	Subsea Electronic Module
SPCS	Subsea Production Control System
TBD	To be Determined
TC	Technical Committee
TCP	Transmission Control Protocol
Torr	mm of Mercury, unit of pressure
Tx	Transmit
UUT	Unit Under Test
VAC	Voltage Alternating Current
VDC	Voltage Direct Current
W	Watt, unit of Power
WG	Working Group (of a TC or SC)
X-HP	Extra-High Pressure

5. Schematic & Terminology

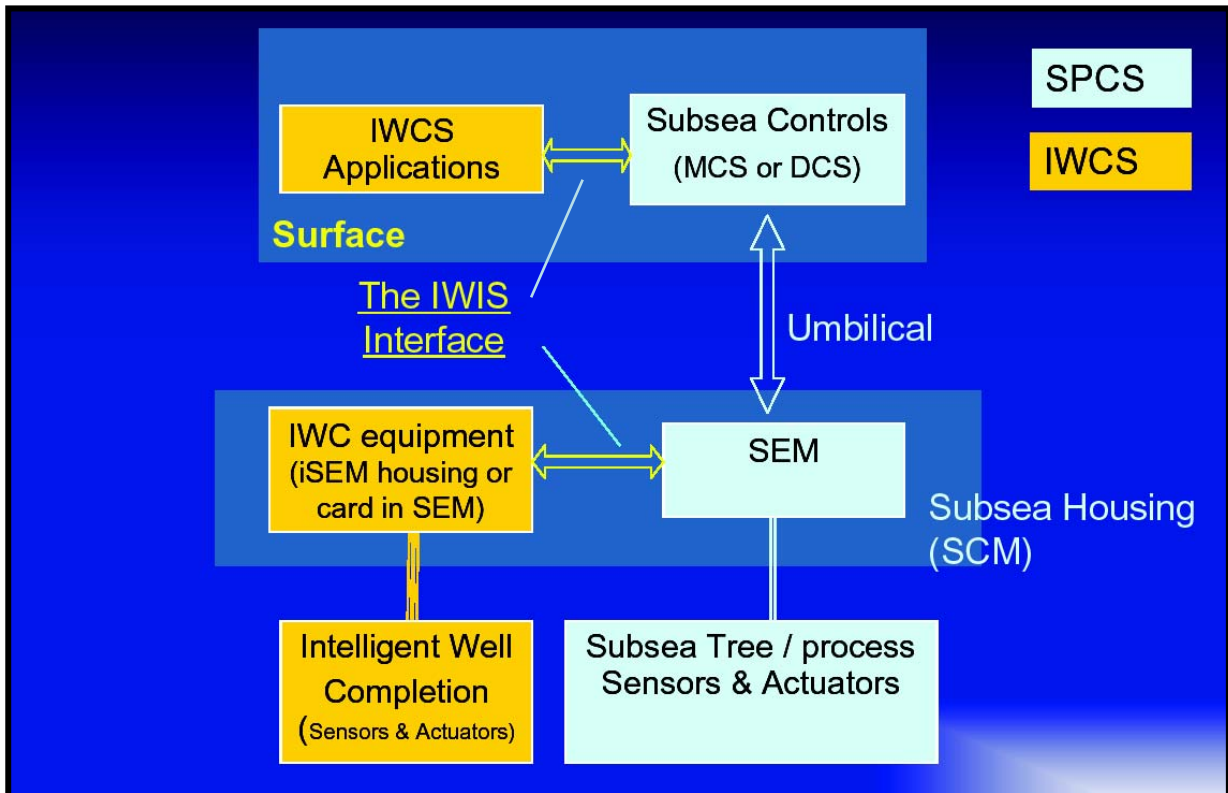

Figure 1 Production Control System & IWIS Schematic



6. Subsea Power System Guidelines

6.1 Introduction

The purpose of this section is to provide supplementary information to ISO 13628-6 (Interface to Intelligent Wells) with regard to the subsea power and physical interface issues that may be encountered when implementing a system.

6.2 Options

6.2.1 Introduction

The standard describes several options (1 to 3). The following sections describe the differences in more detail:

In both low and medium power options, the PCS vendor is responsible for supplying the power and fault isolation to ensure that an IWC equipment failure does not impact the remaining infrastructure. SC note: Power class modified in new ISO text.

The demand from the IWC should be monitored, and if it exceeds the standard and/or the capabilities of the PCS system, the intelligent well equipment may be isolated.

Note: It is possible within the standard to specify an SCM which supports both option 1 and 2.

6.2.2 Option 1 – SEM Interface

Option 1 means that the IWC interface card equipment is located entirely inside of the PCS SEM.

6.2.2.1 Mechanical

The mechanical interface is defined fully in the standard.

The two slot allocation is meant that each will have its own dedicated connector and the minimum spacing shall be according to ANSI 1014-1987 (consecutive slots as defined by IWIS). It should be noted that the spacing may be wider than as per ANSI.

It shall not be possible to mechanically combine the two boards regardless of the ANSI 1014-1987 specifications.

6.2.2.2 Electrical

The IWIS electrical interface between the IWC and the SEM is all contained on the DIN 41612 connectors. There is an expectation that the signals from the IWIS card going to the downhole equipment are connected to the SEM penetrators /connectors, and onward to the downhole equipment.

This is not part of the standard, but the details of voltages and frequency bands should be considered during a system proposal, especially if the voltages or frequencies are large.

It has been agreed in subsequent meetings that the following limits should be considered:

- Voltage max. 300 VAC
- Current max. 1 Ampere

Both connectors shall comply with the same pin allocation defined by IWIS.



6.2.3 Option 2 – SCM Interface

Option 2 is meant to specify a pressure containing canister (iSEM) located either inside or outside the SCM.

6.2.3.1 Mechanical

The mechanical interface is partially defined in the standard. This makes reference to a physical space envelope, complete with clearance for external cables.

6.2.3.2 Electrical

The electrical interface is all contained outside of the PCS SEM, meaning that no IWC equipment is located inside of the SEM.

A basic interface between the PCS SEM and the iSEM has been described, to use 7 connector pins (ISO Annex E2). Further details are not detailed, so the interpretation should be that there would be a minimum of 7 pins/electrical conductors between the SCM and iSEM (this is to account for cabling for the downhole connection). The scope of these connectors and jumpers is to be resolved on a per project basis.

Note: Further emphasis should be placed in the wiring selection criteria between the SEM and iSEM.

The number of iSEM canisters is limited to 1 for compliance, but Subsea Production System supplier could elect to provide space for a second canister to allow for redundancy.

6.2.4 Option 3 – External Interface

All IWC interface equipment is separate to the PCS SCM.

Consistency between Mechanical and Electrical Options should be provided.

Physical option 3 is not defined in the current draft, and therefore the interface details need resolving on a project basis.

6.3 Power Requirements

The standard's interpretation of the power requirements for both the low and medium options, are continuous at 24W and 96W.

6.4 EMC

The design specific nature of EMC issues makes it impossible to provide detailed information, because of this it is strongly recommended that expert advice in the area of EMC design and testing is sought.

6.5 Redundancy

6.5.1 Redundancy Option 1

The SEM provides space for one or two interface cards fitted in Eurocard slots. Should the IWC supplier elect to provide redundant electronics, this needs to be accomplished on the card itself, i.e. the electrical and mechanical interface will not be affected. This applies to systems with single and dual SEMs.

It should be noted that the specification allows for 2 communication channels (RS422) to be connected to one IWC card. Channel A is the primary channel, and channel B is optional.

6.5.2 Redundancy Option 2

The SCM provides a defined space for an iSEM. Should the IWC supplier elect to provide redundant electronics, this needs to be accomplished within the given space envelope, i.e. the electrical and mechanical interface will not be affected. This may mean two canisters or a single canister. This applies to systems with single and dual SEMs.

It should be noted that the specification for option 1 allows for 2 communication channels (RS422) to be connected to one IWC card. Although not explicitly spelled out it is assumed that the iSEM can also be interfaced with 2 x RS422 channels.

6.6 Connection to the Downhole Equipment

The following configurations are foreseen according to the standard although it should be noted that standardisation of wiring within the SCM is not an objective of the IWIS standards.

- Single IWC card – Single Downhole equipment (no redundancy)
- Dual IWC card – Single Downhole equipment (redundant electronics)
- Dual IWC card – Dual Downhole equipment (full redundancy)

This set-up is irrespective of the number of SEMs in the SCM.

The standard connection of 2 x IWIS cards to a single IWE will be connected as shown in figure 2.

The third case is similar to the case detailed in the standard, but everything is doubled.

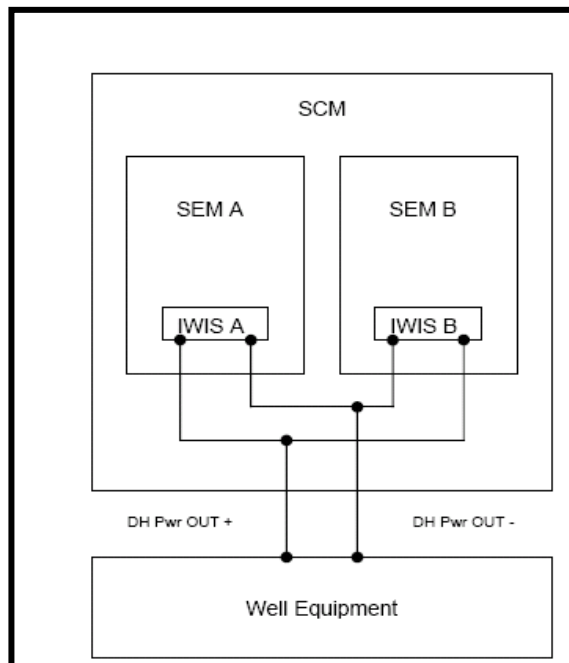

Figure 2 Connection to Downhole Equipment

7. Communication System Guidelines

7.1 Introduction

The purpose of this section is to provide supplementary information to ISO 13628-6 (Interface to Intelligent Wells) with regard to communication systems issues that may be encountered when implementing a system.

7.2 Communications System Overview

IWIS specifies that this interface is physically an RS422 serial link, and specifies also the lower layers of the communications protocol used on this interface. The main elements of this protocol stack are the network (IP) and the transport (TCP) protocol layers, allowing seamless integration of an Intelligent Well Equipment (IWE) into any IP network.

The main idea is that the whole subsea network – from the communications point of view – provides “only” a transparent transport function between the IWE and an Application Software, connected to the subsea network via a Network Access Point. According to this idea, the role of the subsea network is providing the transport function between the above communications partners. This transport function includes support for building, maintaining and releasing a communications link (a TCP connection) between the partners, and also, when the link is open, exchanging messages on that link.

In the IWIS architecture, Application level messages are exchanged between the Application Software and the IWE. Consequently, the SEM <-> IWE link, on which the IWIS interface specification applies, does not “work alone”: you need to establish this link in order to ensure the communications path to the IWE.

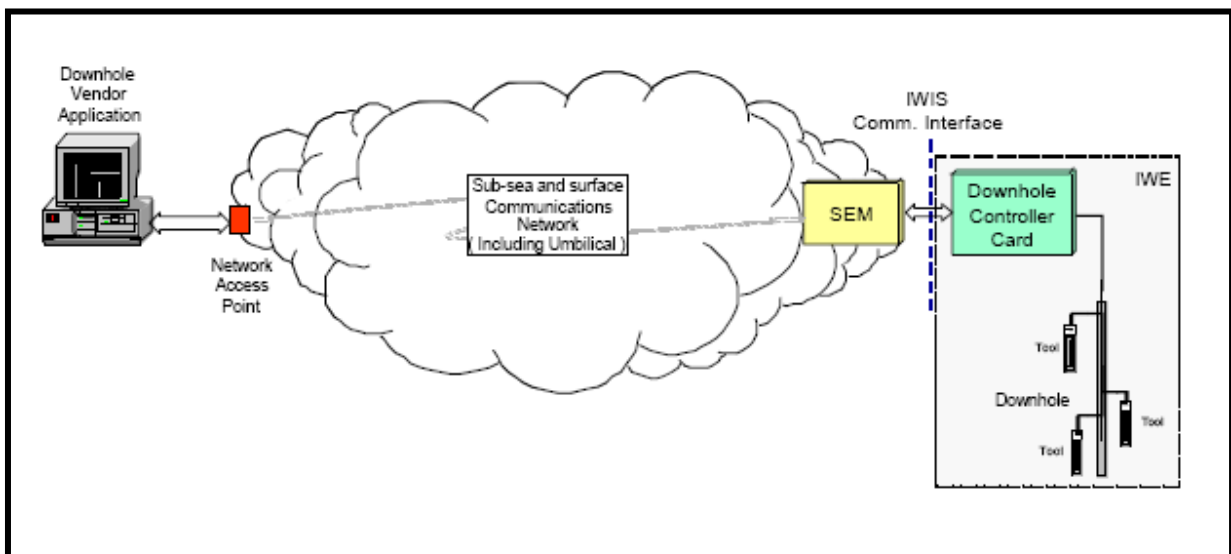

Figure 3 The IWIS Communication Architecture



7.3 Communication System Recommendations

7.3.1 IWIS Serial link Speed

The standard specifies a default value of 9600 bps for the baud rate which must be supported by all subsea and downhole equipment. It is recommended to agree the link speed on a project specific basis to avoid complexity within the system.

Optionally a different link speed could be selected during link establishment though methods of such negotiation are not specified by IWIS or PPP. Methods of such negotiation should be the responsibility of the IWE vendor to implement. An example of such a mechanism may be the IWE attempting to initiate communications at the highest baud rate that it supports, and if communication for the PPP connection is not established, lowering the rate and retrying. This process can be repeated until a successful link is established.

7.3.2 PPP – Introduction

PPP is originally designed as an encapsulation protocol for transporting IP traffic over point-to-point links. PPP provides functions for asynchronous and synchronous encapsulation, network protocol multiplexing, link establishment with optional authentication and link configuration, and options for such capabilities as network layer address negotiation and data-compression negotiation. PPP provides these functions with the help of its components: the extensible Link Control Protocol (LCP) and a family of Network Control Protocols (NCP). The NCP, which is used for IP Protocol configuration – and which shall be discussed here – is called Internet Protocol Control Protocol (IPCP).

PPP connection establishment consists in two or three phases, as follows (the second phase is optional):

- Phase I : Link Establishment using Link Control Protocol (LCP)
- Phase II (optional) : Authentication using Password Authentication Protocol or Challenge-Handshake Authentication Protocol
- Phase III : Network Layer Configuration using Network Control Protocol (NCP) such as Internet Protocol Control Protocol (dedicated to IP configuration).

7.3.3 Establishing the PPP Link

As PPP does not follow a client/server model, all connections are peer-to-peer. To establish communications over a point-to-point link, one of the peers – the ORIGINATOR – must first send an LCP frame to its peer, to the CALLED device. Following this initial request, each of the peers shall send LCP frames to configure and (optionally) test the data link;

- until each sends a Configure_Ack message – meaning that Phase I is terminated, or
- until the connection is broken, or
- until one or both of the peers indicates that the negotiation cannot be completed.

It is also said, that while the ORIGINATOR device is using the PPP connection in ACTIVE mode, the CALLED device is working in PASSIVE mode.

Without entering into the details of the LCP protocol, let us emphasize the principal point here: the two connected devices must play a different, complementary role on the PPP connection establishment process: one must be the ORIGINATOR (ACTIVE) device, and the other the CALLED (PASSIVE) one.

On the SEM <-> IWE link, the originator of the PPP connection establishment (the ACTIVE device) is the IWE. On power-up (or when it detects the disruption of the PPP connection) the IWE shall periodically initiate the PPP connection establishment with its peer device, until this connection is successfully established.



The SEM is playing the role of the called (PASSIVE) device: on power-up (or when it detects the disruption of the PPP connection), it starts to wait for an incoming PPP connection initiation message from the IWE.

Note that both devices may detect the disruption of the PPP connection. The procedure of detecting this disruption (or the “alive” status of the PPP link) could also be specified by IWIS. A recommendation for this function can also be prepared later.

7.3.4 Maintaining Link Status

The Intelligent Well Equipment shall use LCP maintenance packets Echo-Request and Echo-Reply to monitor the connection between the SEM and the IWS. If the link is lost then the “Link Establishment Phase” is re-entered.

7.3.5 IP Address Considerations

This is an introduction to obtaining an IP Address on the PPP link. IP related parameters of the IWE and its peers are negotiated in Phase III of the PPP connection establishment, with the help of the IPCP protocol. Obviously, the key element negotiated in IPCP is each peer’s address.

When the negotiation starts, on entering Phase III, neither device will have an IP address.

The IWE will send a Configure_Req with the address 0.0.0.0. This tells the SEM to assign an address, which is accomplished by the sending of a Configure_Nak with the proper address (see figure 3).

IPCP uses the same packet exchange mechanism as the Link Control Protocol. Consequently, the IP Address negotiation message exchange normally is continued until each peer sends a Configure_Ack message meaning that both ends of the link obtained its IP Address.

IWIS specifies only the issue of assigning / negotiating the IP Address of the IWE: in other words, IWIS does not specify procedures of IP Address assignment for the SEM.

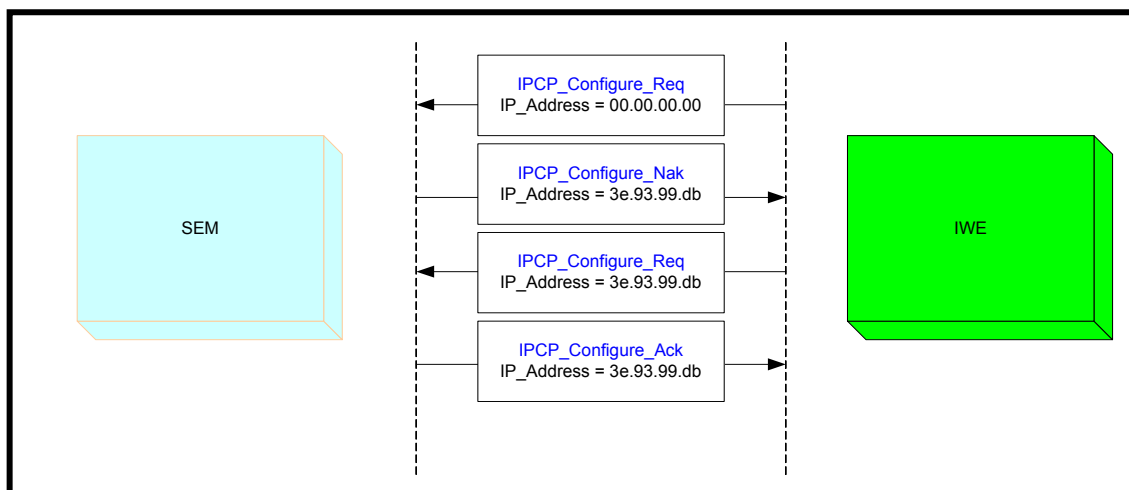

Figure 4 Negotiation of IP Address between IWE and SEM

IWIS specifies only IP Address management procedures for the IWE. Consequently, IWIS expects that the peer station of the IWE (the SEM), has already obtained its IP Address, when entering into Phase III of the PPP link establishment.



According to figure 4, in this case the IWE shall send a Configure_Req IPCP message with 0.0.0.0 IP Address. The response to this message is a Configure_NAK with a valid IP Address. The IWE should send a Configure_Req with this IP Address to obtain the Configure_Ack message.

The algorithm for allocation of IP addresses to the IWE shall be within the scope of the subsea control system. Routines for such allocation could include basing the IP address on the SEM address. The IP addressing algorithm shall provide consistent addressing such that the same IP address remains with the same equipment.

The subsea control system shall make the allocated IP addresses for the IWE equipment available for manual entry into the IWC system.

IWIS interface equipment can have two channels for communications purposes. In this case, each channel shall have its own IP address.

SC note on communication:

7.4 IWCS Interfaces with Other Systems

7.4.1 Introduction

Three options are defined, integrated, stand alone and interfaced, and their system diagrams are in ISO 13628-6.

7.4.2 Integrated

An integrated system means that both the IWC and PCS control system topside elements runs on the same hardware platform (e.g. PC, PLC, unix etc.). Software interfaces are consistent.

7.4.3 Stand Alone

In the stand alone solution, all the intelligent well equipment is controlled from a dedicated Intelligent Well Controller (IWC) on the surface. The IWC equipment uses the two interfaces to communicate and control the well equipment. Once this link has been opened, data can be freely exchanged. PCS equipment manages the transparent PPP link and physical fault isolation, but has no other involvement in the well equipment.

7.4.4 Interfaced

In the interfaced solution, the IWE is controlled from both the IWC surface equipment and the PCS surface equipment. The intention is to allow normal operation of the well equipment from the PCS system, and special operation from the IWC equipment. The IWC equipment uses the two interfaces to communicate and control the well equipment. Once this link has been opened, data can be freely exchanged. PCS equipment manages the transparent PPP link and physical fault isolation. In addition to the stand alone, the IWC surface equipment also hosts a server, where its data is presented to the PCS client.

Because of the decoupling between the intelligent well data content and the PCS system, this interface is needed, as it preserves the independence of the intelligent well system. Only the data points that the PCS system needs, are accessed by the client. Special operation on the IWC is defined by the intelligent well system supplier and there may be restrictions when this is done.

Where the server and client are not on the same hardware, they will interface using

- Layer 1 (Physical) - Twisted Pair Ethernet
- Layer 2 (Data Link) - Ethernet CSMA/CD 10/100Mbps



- Layer 3 (Transport) – IP
- Layer 4 (Message) – TCP

NOTE – Although the IWC surface equipment is separate from the PCS equipment, it may be possible for both parties to share the same hardware platform. Great care should be exercised in this case to ensure that all interfaces are fully tested and defined in isolation.



8. Hydraulic System Guidelines

8.1 Introduction

The purpose of this section is to provide supplementary information to ISO 13628-6 (Interface to Intelligent Wells) with regard to the interface of hydraulic systems.

Intelligent downhole hydraulic control devices are controlled using a single (or multiple) hydraulic supply line(s) from a hydraulic control module on the seabed.

This document details the interface between the production control system SCM, which is provided with hydraulic power from the surface, and the downhole hydraulic device or external IWIS-3 hydraulic control module.

Note: this document does not cover the specification or configuration of the hydraulic connectors between the production control system, wellhead and tubing hanger.

8.2 Interface Options

This recommended practice document details two interface configurations that exist for the hydraulic interface:

- Configuration 1 - Hydraulic supply to downhole device controlled by the production SCM
- Configuration 2 - Hydraulic supply to downhole device controlled by downhole equipment supplier within an IWIS-3 hydraulic module which is supplied by a single hydraulic feed from the subsea production control module.

For configuration 2 the hydraulic functions provided by the downhole hydraulic control system are configurable.

Direct umbilical hydraulic supply and communication/power to downhole hydraulic device or configuration 2 module is outside the scope of this IWIS standard.

Note that it is possible for a production SCM to support both interface options.

8.3 Cleanliness

The cleanliness levels of the fluid supplied to the downhole equipment will be as per ISO13628-Part 6 specification.

8.4 Supply control valve

The solenoid valve in the SCM that controls the hydraulic supply to the downhole hydraulic equipment should be a control valve providing OPEN and VENT TO RETURN functions.

8.5 Compatibility

All parts and components in the system shall be compatible with the production control system selected fluid.

8.6 Thermal Expansion

For Configuration 1, thermal expansion in the downhole supply line is handled by the production control system.

For Configuration 2, thermal expansion in the downhole supply line is handled by the downhole equipment/control system.

8.7 Fail-Safe / Failure Functionality

Any malfunctions or failures within the IWIS hydraulic control module shall not impact the production valve control. Additionally, control of the downhole hydraulic equipment during normal operations shall not impact the production control system valve operation time.

8.8 Interface Options

8.8.1 Configuration 1 – Direct Control

One or more solenoid valves within the production SCM provides control over the supply to the downhole hydraulic device(s).

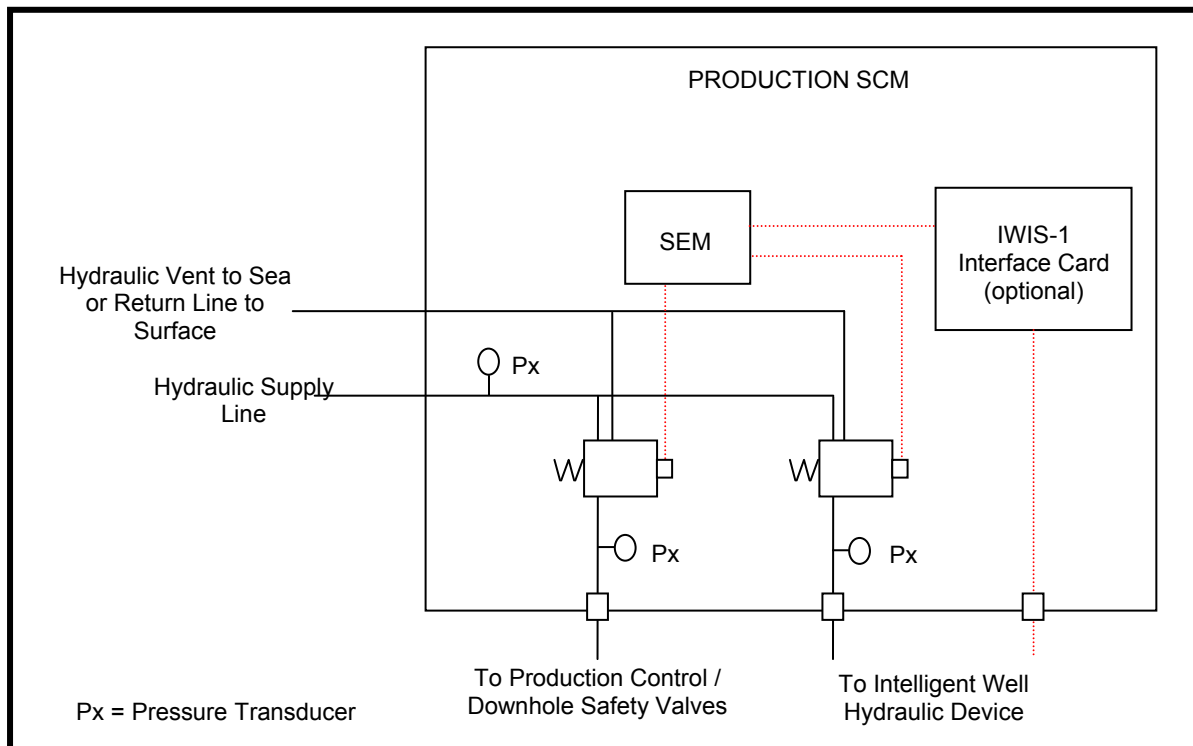

Figure 5 Hydraulic Interface Direct Control

The control of these valves as well as the monitoring of the supply pressure for the line is provided by the production control system and will be available to the downhole vendor surface acquisition and control system on the surface.

If required, the production control system will be able to override the downhole vendor command to the valves during emergency shutdowns or production valve operations to ensure safety operations are not compromised.

The return line from the downhole hydraulic control line will be tied back into the production control system return line, see figure 5.

8.8.2 Configuration 2 – IWIS Option 3 Hydraulic Module

This hydraulic interface has the downhole hydraulic control module external to the production SCM as detailed by the IWIS-3 option. A controlled hydraulic supply to the downhole vendor module is provided by the production SCM or via a direct hydraulic supply line from the surface.

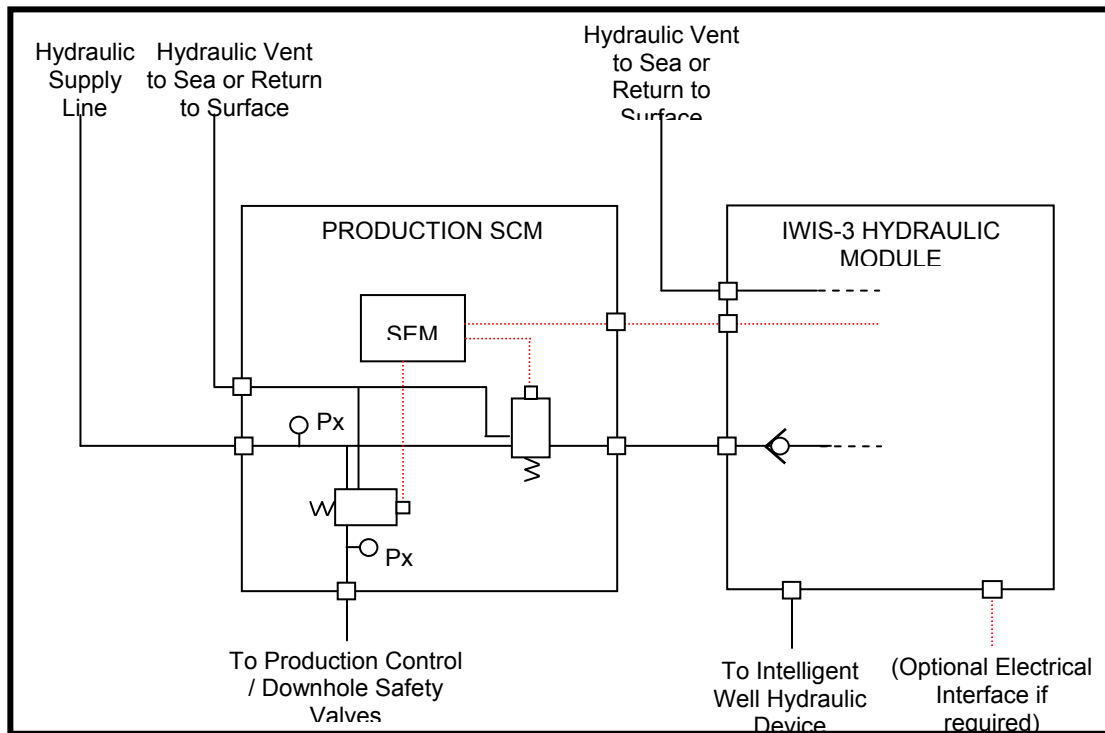

Figure 6 Hydraulic Interface IWIS Option 3 Hydraulic Module

The return fluid is either vented locally or delivered to surface via a dedicated return line. A check valve in the IWIS-3 hydraulic module is used to protect the SCM hydraulic supply, see figure 6.

Control of hydraulic system is provided by the downhole vendor via an IWIS electrical interface and removal of the SCM or hydraulic module shall leave the downhole system as is and result in no fluid loss or compromise to production SCM control. The production system may inhibit downhole hydraulic control during controlled safety shut-downs.

All monitoring and control of the IWIS-3 hydraulic module sensors and valves is performed by the downhole vendor control system via an IWIS electrical interface.

This configuration allows the hydraulic module to be installed and retrieved without affecting the production module.



9. Xmas Tree Physical Interface System Guidelines

9.1 Introduction

The purpose of this section is to provide specific design, functional specification, qualification and acceptance testing requirements for an Electrical Feedthrough System (EFS) to be used in intelligent well applications using vertical or horizontal subsea Xmas Trees (wellhead system). Refer to the generic configurations detailed in figures 7 and 8.

9.2 EFS Function

The primary function of the EFS is to facilitate tree/tubing hanger electrical communication between permanently installed downhole instrumentation (sensors, gauges) and a surface located data control system while providing full pressure-containment through the wellhead system.

The EFS consists of one or more wet-mate and dry-mate electrical connectors interconnected as needed to establish and maintain electrical circuit isolation through the various wellhead system components. Interface details between the connector elements and the end user's equipment are outside the scope of this specification. However, the connectors and interfaces must be suitable for the conditions described in this specification.

9.3 Service Classes

There are three classes for pressure and temperature ratings for operational and test levels:

Service Class & Rating	Class A	Class B	Class C
Temperature Range (T_T)	-18 to +121°C (This coincides with API 6A U Class temperature rating)	-18 to +150°C	-18 to +177°C (This coincides with API 6A U Class temperature rating)
Wellhead Internal Pressure (P_w)	0 to 690 Bar a	0 to 1034 Bar a	0 to 1034 Bar a
External Seawater Hydrostatic Working Pressure (P_w)	345 Bar a (maximum)	455 Bar a (maximum)	455 Bar a (maximum)
Deployment Water Depth	0 to 3,000m	0 to 4,500m	0 to 4,500m

Table 3 Service Classes

9.4 Documentation

It is the responsibility of the client and the EFS manufacturer to determine the necessary level of documentation necessary to confirm the design is fit-for-purpose for the client's application through qualification testing, and to identify in-process production and delivery functional verification of the product.

Typical documentation includes the following:

- Factory Acceptance Test (FAT) procedures
- Handling, Shipping and Storage procedures
- Installation, Deployment and Maintenance procedures
- Qualification Test documentation
- Reliability documentation
- Design Summary

9.5 Critical Interfaces

The feedthrough design shall address and account for the critical interfaces that exist between the external, subsea interface to the Subsea Control Module (SCM), and the internal interface to the downhole gauge (DHG) cable (control line).

The physical and mechanical interfaces within the Xmas Tree are to be determined through collaboration between the EFS supplier and the Xmas Tree supplier.

9.6 System Configurations

9.6.1 Horizontal Xmas Tree Feedthrough System Configuration

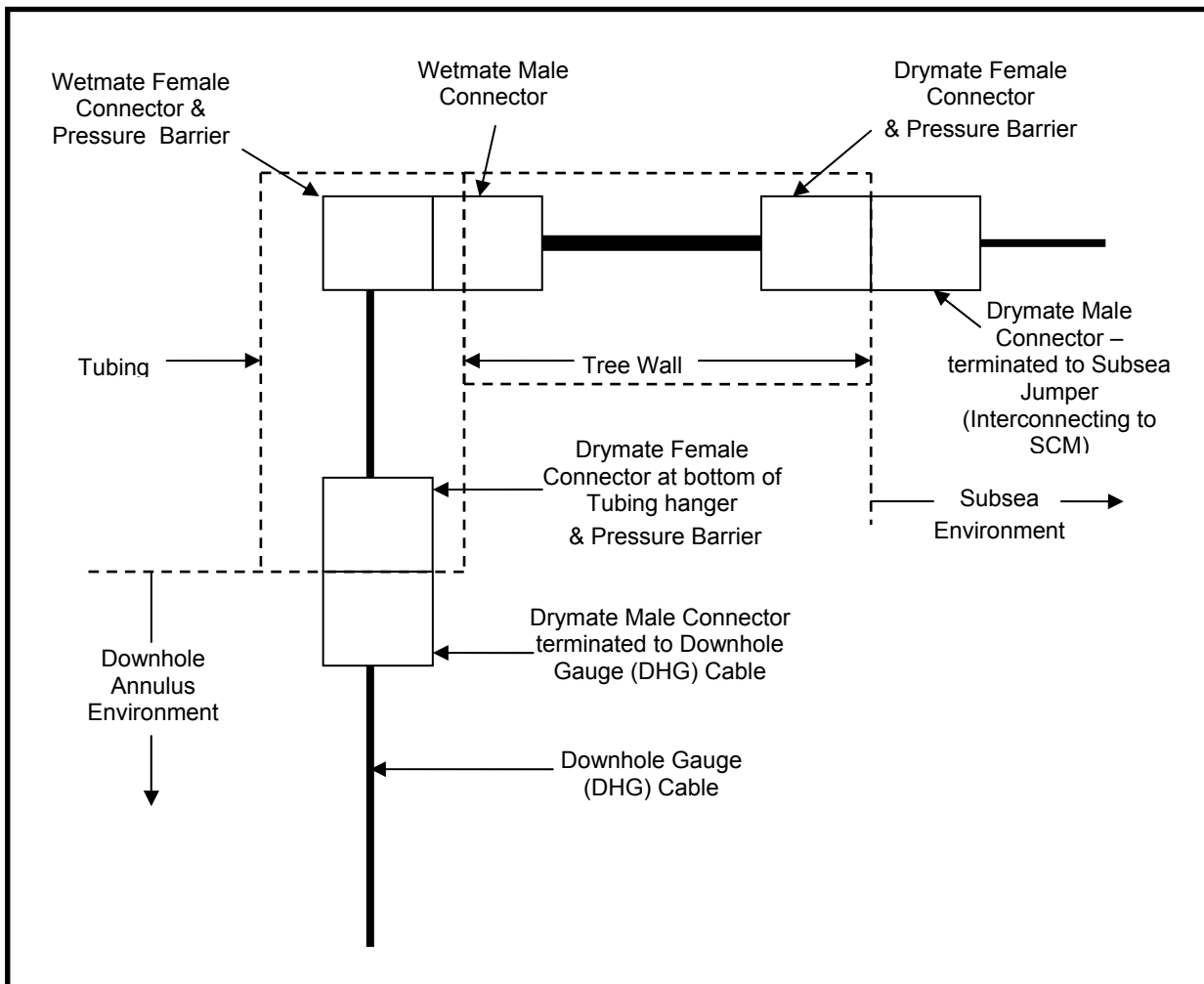

Figure 7 Horizontal Xmas Tree Feedthrough System Configuration

9.6.2 Vertical Xmas Tree Feedthrough System Configuration

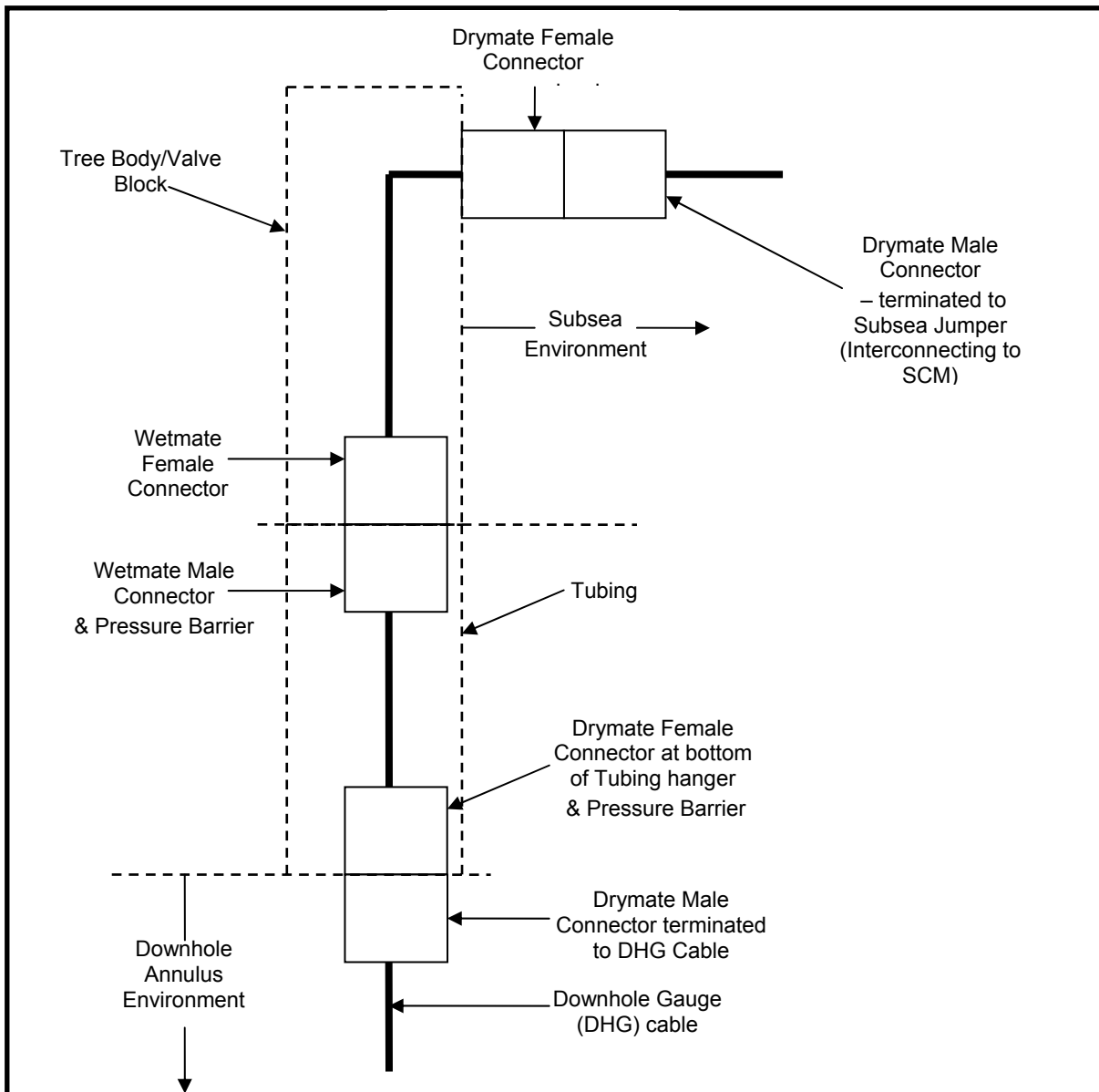

Figure 8 Vertical Xmas Tree Feedthrough System Configuration

9.7 Reliability

Reliability of the connector / penetrator system is critical.

The design shall take into consideration all aspects of the operations involved with delivery, storage, installation and use of the system and components. Of particular importance is the installation of offshore components.

The design objective shall result in as simple and robust a design as possible minimizing the possibility of premature failure.

Due consideration shall be given to failure mode effects and critical analysis (FMECA) during the design process.



9.8 Service Conditions

9.8.1 Design

Design in accordance with:

- ISO 10423 (API 6A) – PSL3 and PR2
- API 17D
- NACE – MR0175
- ISO 13628-3

9.8.2 Service Conditions

Service Conditions	Class A	Class B	Class C
Temperature Range (T _T)	-18 to +121°C	-18 to +150°C	-18 to +177°C
Wellhead Internal Working Pressure (P _w)	0 to 690 Bar a	0 to 1034 Bar a	0 to 1034 Bar a
Internal Test Pressure (P _T = 1.5 x P _w)	0 to 1034 Bar a	0 to 1551 Bar a	0 to 1551 Bar a
External Seawater Hydrostatic Working Pressure (P _w)	0 to 345 Bar a	0 to 455 Bar a	0 to 455 Bar a
External Test Pressure (P _T = 1.5 x P _w)	0 to 517 Bar a	0 to 683 Bar a	0 to 683 Bar a
Deployment Water Depth	0 to 3,000m	0 to 4,500m	0 to 4,500m

Table 4 Service Conditions

9.8.3 Storage

Storage temperature range: -40° to 70°C

9.8.4 Chemicals

Chemical exposure: Suitable for API 6A material class HH

Chemical exposures will include common liquid and gaseous phases typical of a well completion in the gallery and annulus, as well as subsea. The following is a representative list of typical chemicals that can be present:

Seawater, hydrocarbon production fluids, diesel, mineral oil-based, synthetic and water-based control fluid, glycol/MEG, calcium bromide, calcium chloride, hydrogen sulphide, carbon dioxide, methanol, zinc bromide, silicone oil, oxygen scavengers, corrosion inhibitors, citric acid, acetic acid.

Note: This is a list of chemicals that may be present in a given application. Specific applications may involve different chemical compositions and it is common for the EFS manufacturer and the client to determine and agree on sufficient chemical compatibility testing completed, or conduct additional testing as required.



9.9 Mechanical Performance Requirements

Mechanical Criteria	Performance Requirements
Maximum allowable mate / de-mate force:	500 N (112 lbf).
Minimum mate / de-mate cycle life:	100 mates in turbid sand, salt and water.
Connector shear load resistance:	Horizontal Tree: Maximum 6.75 metric tons.
Hydrocarbon Seal Configuration:	Seals of dissimilar designs and materials are required for all pressure boundaries / barriers. Metal seals are preferred for all primary seals.
Misalignment Engagement	All configurations shall be "scoop proof" such that the contact elements are fully protected during misalignment.
Keyed Interfaces	Keyed interfaces will be required if orientation is critical.
Connector Inter-changeability	Connectors shall be interchangeable (inter-mateable) between mating halves and shall not be matched sets.
Debris	The wetmate interface shall be designed to be tolerant of debris present in the interface during normal mating operations.

Table 5 Mechanical Performance Requirements

9.10 Electrical Performance Requirements

Electrical Criteria	Performance Requirements		
Maximum working voltage	600 VDC.		
Test voltage	2400 VDC.		
Maximum working current	5.0 Amp.		
Maximum contact resistance	< 30 mohm with 2.0 A load (excluding test leads) per contact pair.		
Insulation Resistance	IR (min) of component level, room temperature	IR (min) of system level, room temperature	IR (min) of system level, at max. temperature (T _T)
Qualification	10.0 GΩ @ 1000VDC, 1 minute duration.	1.0 GΩ @ 1000VDC, 1 minute duration.	20.0 MΩ @ 1000VDC, 1 minute duration.
FAT	10.0 GΩ @ 500VDC, 1 minute duration.	1.0 GΩ @ 500VDC, 1 minute duration.	Not Required.

Table 6 Electrical Performance Requirements

9.11 Qualification Test Requirements

The following basic electrical tests are to be performed at various stages during the test program to demonstrate electrical integrity is in conformance with the requirements. All electrical tests shall be conducted in typical atmospheric conditions unless noted otherwise.

9.11.1 Contact Resistance Test (CR)

Criteria	Performance
Number of connectors to be tested	All contact pairs.
Test conditions and durations	Apply 2 Amp load and measure resistance.
Test Acceptance Criteria	< 30 mΩ (excluding test leads).

Table 7 Contact Resistance



9.11.2 Insulation Resistance Test (IR)

Criteria	Performance
Number of connectors to be tested	All.
Test conditions and durations	Apply 1,000 VDC for 1 minutes and measure resistance.
Test Acceptance Criteria	1.0 GΩ minimum for mated system level. 10.0 GΩ individual component level.

Table 8 Insulation Resistance

9.11.3 Proof Voltage Test (HV)

Criteria	Performance
Number of connectors to be tested	All.
Test conditions and durations	Apply 2400 VDC for 1 minute in accordance with IEC 60502-1.
Test Acceptance Criteria	No evidence of insulation breakdown or flashover.

Table 9 Proof Voltage

9.11.4 Hydrostatic Withstand Pressure Test (HWPT)

Criteria	Performance		
Connectors to be Tested	Individual pressure barrier components; open-face and reverse-face exposure Mated integrity of all connections interfaces.		
Test Conditions & Durations	Proof voltage testing (HV) shall be conducted before and after pressure exposure.		
	For open-face (unmated) pressure testing, insulation resistance shall be measured before and after pressure exposure. Test pressure exposure shall be P _T per Table 3.0.		
	For reverse-face pressure testing, insulation resistance shall be measured before and after pressure exposure. Test pressure exposure shall be P _W per Table 3.0.		
	For mated integrity pressure exposure, insulation resistance and continuity shall be measured in the pressure vessel at zero and maximum pressures. Test pressure exposure shall be P _W per Table 3.0.		
Acceptance Criteria	Once pressure has stabilized there shall be no evidence of pressure loss. Pressure vessel stability per current revision of API 6A (±5%) or 34.5 Bar a whichever is lower. Deviations from the initial stabilized pressure due to temperature variation are acceptable. After test: No visible damage or pressure leakage Contact Resistance: < 30 mΩ per contact pair (excludes leads) Insulation Resistance: 1.0 GΩ minimum for mated system level Insulation Resistance: 10.0 GΩ individual component level Proof Voltage: No evidence of insulation breakdown or flashover		
Cycle	Pressure and duration	Temperature	Comment
1	15 minutes @ test pressure	ambient	Apply pressure, hold, then lower to zero psig.
2	15 minutes @ test pressure	ambient	Apply pressure, hold, then lower to zero psig.
3	60 minutes @ test pressure	ambient	Apply pressure, hold, then lower to zero psig.
4	15 minutes @ 52 Bar a	ambient	Apply pressure, hold, then lower to zero psig.

Table 10 Hydrostatic Withstand Pressure Test



9.11.5 Functional Mate / De-mate Test in Turbid Conditions

Criteria	Performance
Number of wetmate connectors to be tested	1 pair
Test Conditions & Durations	<p>Perform initial electrical tests at room temperature and atmospheric pressure prior to commencing test.</p> <p>Bench test connectors (drymate); mate / de-mate connectors 5 times. Repeat electrical tests after drymate tests and prior to commencing wetmate test. Proof voltage testing (HV) shall be conducted only before and after wetmate cycling.</p> <p>Establish the test media consisting of simulated seawater (35,000 PPM NaCl), 1% river silt (2 to 50µm) and 0.5% sharp sand (50 to 500µm) while maintaining agitation of solution throughout test.</p> <p>Install UUT into test apparatus and stabilize temperature at first mating cycle shall be submerged (wet) at atmospheric pressure – all subsequent mating cycles shall be submerged (wet).</p> <p>Second mating cycle shall be at 173 Bar a. Balance of mating cycles to 100 shall be at maximum external seawater hydrostatic working pressure (P_w).</p> <p>Contact and insulation resistance to be measured and recorded at pressure as follows: After cycle 1, 2, 3, 4 & 5, cycle 10 and every 10 cycles thereafter. Final readings shall be taken at ambient pressure.</p>
Acceptance Criteria	<p>Once pressure has stabilized there shall be no evidence of pressure loss. Pressure vessel stability per current revision of API 6A (±5%) or 34.5 Bar a whichever is lower.</p> <p>Deviations from the initial stabilized pressure due to temperature variation are acceptable.</p> <p>No visible damage or pressure leakage.</p> <p>Contact Resistance: < 30 mΩ per contact pair (excludes test leads)</p> <p>Insulation Resistance: 1.0 GΩ minimum for mated system level</p> <p>Insulation Resistance: 10.0 GΩ individual component level</p> <p>Proof Voltage: No evidence of insulation breakdown or flashover</p>

Table 11 Turbid Testing



9.11.6 Misalignment Test

Criteria	Performance		
Number of wetmate connectors to be tested	1 pair.		
Test Conditions & Durations	Perform basic electrical tests prior to commencing test. Establish maximum misalignment per Table 15 between wetmate connector halves.		
	Pressure:	1.5 x external working pressure (P _w)	
	Temperature:	Room temperature	
Acceptance Criteria	Environment:	Tap water	
	Duration:	8 mating cycles minimum with 2 misalignment mating cycles in each of the following quadrants: +x/+y, +x/-y, -x/+y, -x/-y	
	Note: Although it is preferred, it is not mandatory to conduct this test wet, under pressure - the test may be conducted under atmospheric conditions.		
Misalignment Mode	Vertical Penetrator	Horizontal Penetrator	
	Radial Tolerance	± 1.0 mm	± 0.75 mm
	Axial Tolerance	± 5.1 mm	± 1.5 mm
	Angular Tolerance	N/A	± 0.4 °
	Mating Engagement Rate	0.3m/sec	12.5mm/sec
	Proof Voltage:	No evidence of insulation breakdown or flashover	

Table 12 Misalignment Test



9.11.7 Thermal Shock Test

Criteria	Performance
Number of connectors to be tested	Minimum of 2 pairs.
Test Conditions & Durations	<p>The following tests are conducted at atmospheric pressure and shall demonstrate that thermal shock will have no detrimental effect on the connector and feedthrough assembly. Each assembly shall be tested in its final assembled state in an unmated condition.</p> <p><u>High Temperature Test:</u> 70°C for 4 hours to 3°C x 3 cycles @ ambient pressure. Perform basic electrical tests prior to commencing test. Bring the UUT up to the maximum test temperature of 70°±4°C and permit to dwell for 4 hours. Rapidly immerse the UUT in water bath maintained at 3°±3°C and permit to dwell for 4 hours. Repeat this cycle a total of three times. Permit UUT to recover to room temperature and repeat electrical tests in a mated and unmated condition.</p> <p><u>Low Temperature Test:</u> -40°C for 4 hours to 3°C x 3 cycles @ ambient pressure. Perform basic electrical tests prior to commencing test. Bring the UUT down to -40°±4°C in an environmental chamber and permit to dwell for 4 hours. Rapidly immerse the UUT in water bath maintained at 3°±3°C and permit to dwell for 4 hours. Repeat this cycle a total of three times. Permit UUT to recover to room temperature and repeat electrical tests in a mated and unmated condition.</p>
Acceptance Criteria	<p>No visible damage.</p> <p>Insulation Resistance: 1.0 GΩ minimum for mated system level.</p> <p>Insulation Resistance: 10.0 GΩ individual component level.</p>

Table 13 Thermal Shock Test



9.11.8 Flooded Termination Test

Criteria	Performance
Number of connectors to be tested	1 of each uniquely different terminated component (identical terminations used in multiple locations only require a single type-test to qualify). UUT shall have only the final barrier of the electrical isolation system intact simulating a flooded termination.
Test Conditions & Durations	<p>Insulation resistance and continuity shall be initially measured on the UUT in a pressure vessel, wetted, but at ambient pressure and temperature. The vessel temperature and pressure shall be raised to the maximum test temperature (T_T) and working pressure (P_W) as defined in Table 6, and maintained under these conditions for a period of 1200 hours (50 days). Throughout the test period, insulation resistance and continuity shall be measured and recorded twice daily during normal working hours.</p> <p>Upon completion of the test period, the pressure and temperature shall be permitted to gradually return to ambient with insulation resistance and continuity measured and recorded prior to removal from the vessel.</p> <p>Once pressure has stabilized there shall be no evidence of pressure loss. Pressure vessel stability per current revision of API 6A ($\pm 5\%$) or 34.5 Bar a whichever is lower. Deviations from the initial stabilized pressure due to temperature variation are acceptable.</p>
Acceptance Criteria	<p>No visible damage or pressure leakage.</p> <p>Insulation Resistance: 1.0 GΩ minimum for mated system level.</p> <p>Insulation Resistance: 10.0 GΩ individual component level.</p> <p>Insulation Resistance: 20.0 MΩ @ T_T and P_W as defined in Table 3.0.</p>

Table 14 Flooded Termination Test



9.11.9 Individual Seal Hydrostatic Pressure Test

Criteria		Performance	
Connectors to be Tested		1 pair.	
Test Conditions & Durations		Individual primary pressure-containment seals are to be installed at relevant interfaces with secondary seals not installed, removed or negated, and pressure (P_T) tested per Tables 4 and 15.	
		Individual secondary pressure-containment seals are to be installed at relevant interfaces with primary seals not installed, removed or negated, and pressure (P_T) tested per Tables 4 and 15.	
		For bi-directional seals, whether primary or secondary, pressure (P_T) test individually per Tables 4 and 15.	
Acceptance Criteria		<p>Once pressure has stabilized there shall be no evidence of pressure loss. Pressure vessel stability per current revision of API 6A ($\pm 5\%$) or 34.5 Bar a whichever is lower.</p> <p>Deviations from the initial stabilized pressure due to temperature variation are acceptable.</p> <p>After the test:</p> <p>No visible damage or pressure leakage (note any damage evident on seals)</p> <p>Contact Resistance: < 30 mΩ per contact pair (excludes test leads)</p> <p>Insulation Resistance: 1.0 GΩ minimum for mated system level</p> <p>Insulation Resistance: 10.0 GΩ individual component level</p>	
Cycle	Pressure and duration	Temperature	Comment
1	15 minutes @ test pressure (P_T)	ambient	Apply pressure, hold, then lower to zero psig.
2	15 minutes @ test pressure (P_T)	ambient	Apply pressure, hold, then lower to zero psig.
3	60 minutes @ test pressure (P_T)	ambient	Apply pressure, hold, then lower to zero psig.
4	15 minutes @ 52 Bar a	ambient	Apply pressure, hold, then lower to zero psig.

Table 15 Seal Hydrostatic Pressure Test



9.11.10 Mechanical Shock Test

Criteria	Performance
Number of connectors to be tested	1 pair of each unique interface (unmated).
Test Conditions & Durations	Perform basic electrical tests prior to commencing test.
	3 x shocks in the axial axis (parallel to centreline).
	3 x shocks in the radial axis (perpendicular to centreline).
	Shock profile: Half-sine period of 11ms @ 30g.
Acceptance Criteria	No visible damage. Contact Resistance: < 30 mΩ per contact pair (excludes test leads) Insulation Resistance: 1.0 GΩ minimum for mated system level Insulation Resistance: 10.0 GΩ individual component level Proof Voltage: No evidence of insulation breakdown or flashover

Table 16 Mechanical Shock Test

9.11.11 Vibration Test:

Criteria	Performance
Number of connectors to be tested	1 pair.
Test Conditions & Durations	Perform basic electrical tests prior to commencing test.
	Excitation to be applied to three mutually perpendicular axes.
	5 Hz to 25 Hz ± 2mm displacement.
	25 Hz to 150 Hz 5g acceleration.
	Sweep rate maximum one octave per minute.
A double sweep from 5 Hz to 150 Hz and back to 5 Hz shall be performed.	
Acceptance Criteria	No visible damage. Contact Resistance: < 30 mΩ per contact pair (excludes test leads) Insulation Resistance: 1.0 GΩ minimum for mated system level Insulation Resistance: 10.0 GΩ individual component level Proof Voltage: No evidence of insulation breakdown or flashover

Table 17 Vibration Test



9.11.12 Cyclical Pressure and Temperature Test (API PR2 type)

Criteria	Performance
Number of connectors to be tested	Complete feedthrough system comprising wet and drymate connectors.
Test Conditions & Durations	Test is required to qualify the wet and drymate connectors in a full-up, mated system configuration in accordance with API 6A, F1.11.3.
	Temperature range: Ambient to T_T per Table 3 and -18°C Pressure range: 0psig to P_W per Table 3 Number of P/T cycles: 3 Test media: Tap water with adequate protection to prevent freezing
Acceptance Criteria	During test: Electrical continuity and insulation resistance to be monitored throughout the test. There shall be no malfunction of the system electrical performance throughout test exposure. Pressure vessel stability per current revision of API 6A ($\pm 5\%$) or 34.5 Bar whichever is lower. IR shall remain at 20.0 M Ω or higher through exposure.
	After test: No visible damage or pressure leakage. Contact Resistance: < 30 m Ω per contact pair (excludes test leads) Insulation Resistance: 1.0 G Ω minimum for mated system level Insulation Resistance: 10.0 G Ω individual component level Proof Voltage: No evidence of insulation breakdown or flashover

Table 18 Cyclical Pressure & Temperature Test

9.11.13 Helium Leak Test

Criteria	Performance
Number of connectors to be tested	All individual pressure barrier components.
Test Conditions & Durations	Test is required to verify the integrity of all pressure barrier internal sealing elements.
	Using a mass spectrometer, a vacuum shall be applied to one side of the UUT to achieve a threshold of approximately 10mTorr or less. Helium shall then be applied to the atmospheric face of the UUT. The helium leak rate shall be recorded after 1 minute exposure. Temperature: Room temperature.
Acceptance Criteria	Helium leak rate shall be less than $1 \times 10^{-6} \text{ cm}^3/\text{sec}$.

Table 19 Helium Leak Test

9.11.14 Shell Continuity Test

Criteria	Performance
Number of connectors to be tested	Mated wet and dry-mate connectors.
Test Conditions & Durations	This test is required to verify the electrical continuity between the connector shells when mated. The measurement shall be made from the back diameter of each mated connector body at a point furthest from the mating interface.
	Temperature: Room temperature. Pressure: Atmospheric pressure.
Acceptance Criteria	Shell continuity shall be less than 0.1 Ω .

Table 20 Shell Continuity Test



9.12 Factory Acceptance Test (FAT)

9.12.1 Introduction

As a minimum, the FAT shall demonstrate that all connectors and delivered assemblies conform to the electrical and mechanical specifications as stated herein.

9.12.2 Tests

These tests shall include as a minimum the following type tests:

Test	Conditions and Durations	Acceptance Criteria
Contact Resistance	Apply 2A load and measure resistance.	< 30 mΩ per contact pair (excludes test leads).
Insulation Resistance	Apply 500 VDC for 1 minute and measure resistance.	10.0 GΩ for individual component level.
Proof Voltage	Apply 2400 VDC for 1 minute.	No evidence of insulation breakdown or flashover.
Helium Leak	<p>Number of connectors to be tested: All individual pressure barrier components.</p> <p>Test is required to verify the integrity of all pressure barrier internal sealing elements.</p> <p>Test to be at Room Temperature.</p> <p>Using a mass spectrometer, a vacuum shall be applied to one side of the UUT to achieve a threshold of approximately 10mTorr or less. Helium shall then be applied to the atmospheric face of the UUT. The helium leak rate shall be recorded after 1 minute exposure.</p>	Helium leak rate shall be less then $1 \times 10^{-6} \text{ cm}^3/\text{sec}$.
Hydrostatic Withstand Pressure	<p>Connectors to be tested:</p> <ol style="list-style-type: none"> Individual pressure barrier components (open-face exposure) Deliverable assemblies <p>Proof voltage testing shall be conducted before and after pressure exposure.</p> <p>Insulation resistance shall be measured before and after pressure exposure. For individual pressure barrier components, the test pressure exposure shall be P_T per Table 10. For deliverable assemblies, the test pressure exposure shall be P_W per Table 10.</p>	<p>Once pressure has stabilized there shall be no evidence of pressure loss.</p> <p>Pressure vessel stability per current revision of API 6A ($\pm 5\%$) or 34.5 Bar a whichever is lower.</p> <p>Deviations from the initial stabilized pressure due to temperature variation are acceptable.</p> <p>After test:</p> <p>No visible damage or pressure leakage.</p> <p>Insulation Resistance: 1.0 GΩ minimum for mated system level.</p>

Table 21 Factory Acceptance Test